



(19) **United States**

(12) **Patent Application Publication**
DUAN et al.

(10) **Pub. No.: US 2016/0163263 A1**
(43) **Pub. Date: Jun. 9, 2016**

(54) **PIXEL CIRCUIT, DRIVING CIRCUIT, ARRAY SUBSTRATE AND DISPLAY DEVICE**

Publication Classification

(71) Applicant: **BOE Technology Group Co., Ltd.**,
Beijing (CN)
(72) Inventors: **Liye DUAN**, Beijing (CN); **Lirong WANG**, Beijing (CN); **Zhongyuan WU**,
Beijing (CN)

(51) **Int. Cl.**
G09G 3/32 (2006.01)
(52) **U.S. Cl.**
CPC **G09G 3/3258** (2013.01); **G09G 3/3283**
(2013.01); **G09G 2310/0264** (2013.01); **G09G**
2320/043 (2013.01); **G09G 2300/0809**
(2013.01)

(73) Assignee: **BOE TECHNOLOGY GROUP CO., LTD.**, Beijing (CN)

(57) **ABSTRACT**

The present disclosure relates to the OLED display technology. There are provided a pixel circuit, a driving circuit, an array substrate and a display device, which are supplied with the voltage by the light emitting operation voltage when the pixel circuit enters the light emitting stage, by inputting an inverse signal synchronized with the pre-charging control voltage at the input terminal of the light emitting operation voltage to ensure a stable output of the current by the circuit at the light emitting stage. Also, it does not require an arrangement of an external voltage input terminal which will affect the aperture ratio, thereby increasing the aperture ratio of the OLED employing the current-driven pixel circuit while ensuring the stable output of the current by the current-driven circuit, and thus increasing the lifetime of the OLED employing the current-driven pixel circuit.

(21) Appl. No.: **14/366,865**

(22) PCT Filed: **Dec. 12, 2013**

(86) PCT No.: **PCT/CN2013/089155**

§ 371 (c)(1),
(2) Date: **Jun. 19, 2014**

(30) **Foreign Application Priority Data**

Sep. 9, 2013 (CN) 201310407319.1

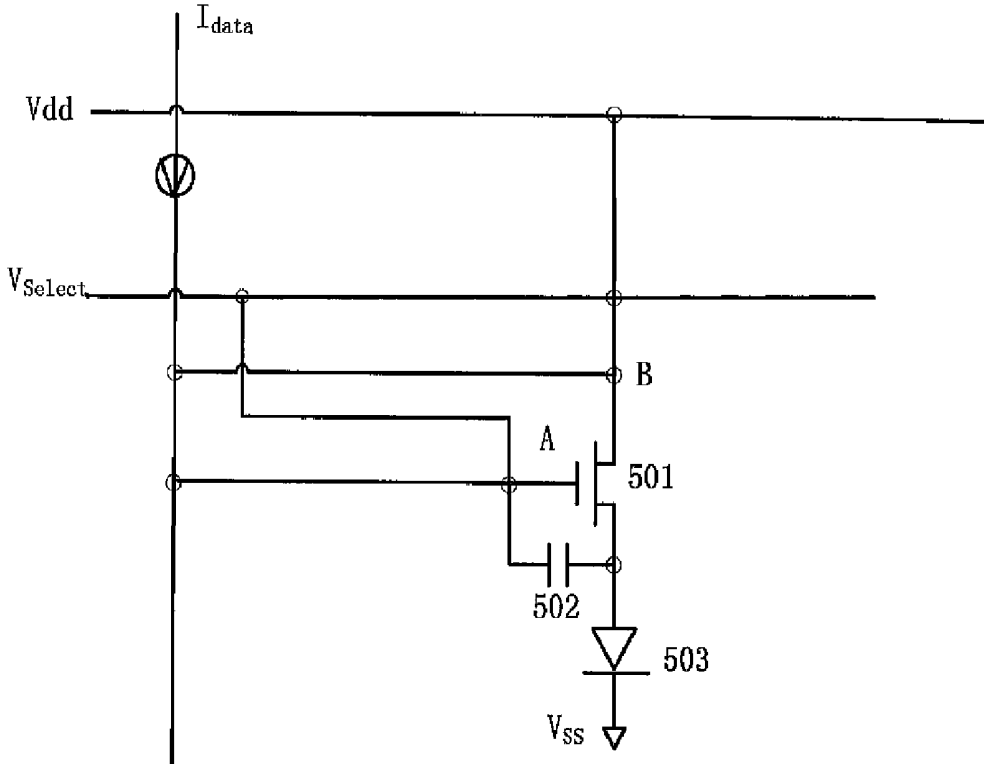

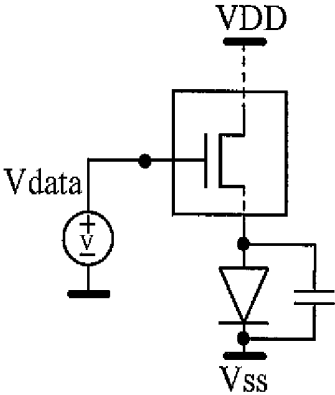

Figure 1

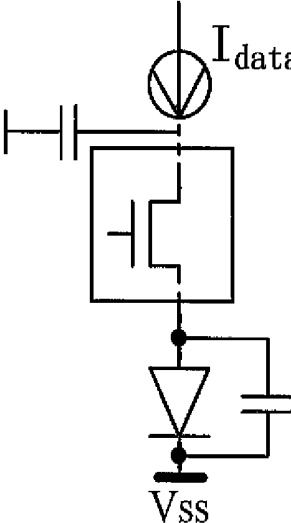

Figure 2

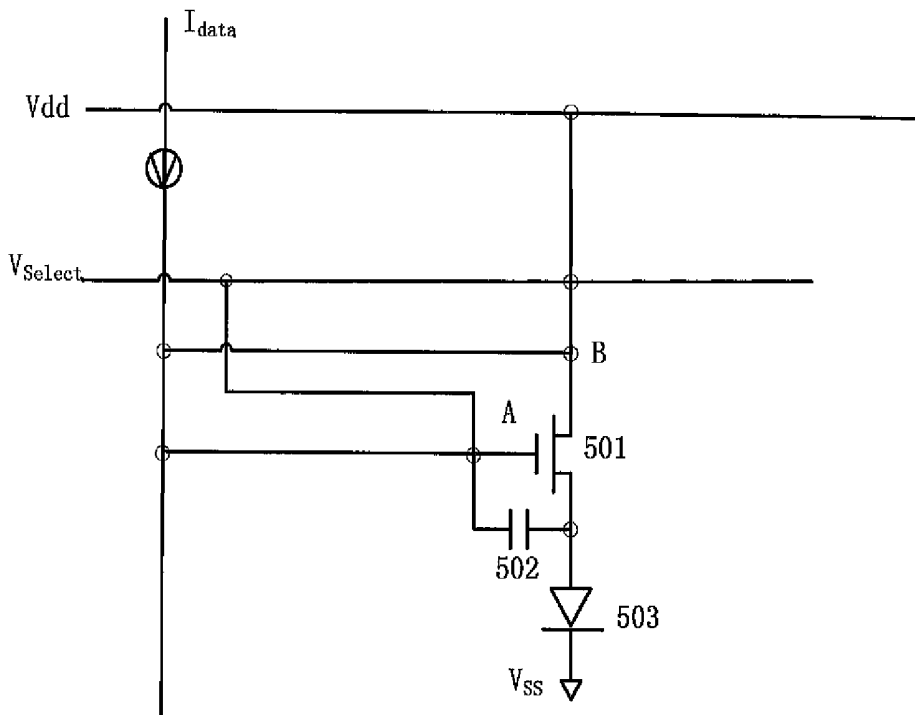

Figure 5

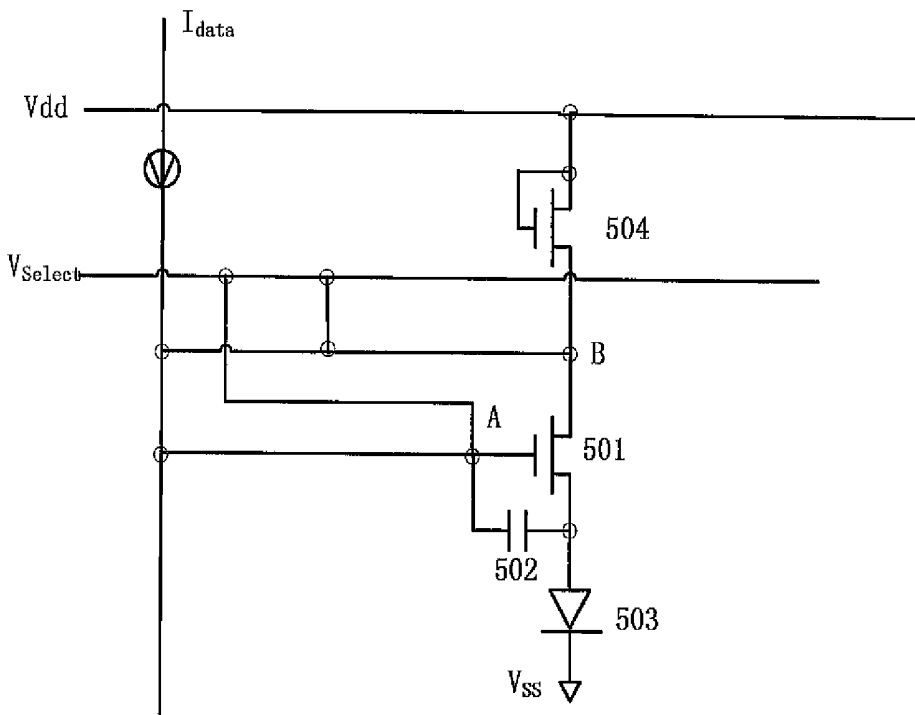

Figure 6

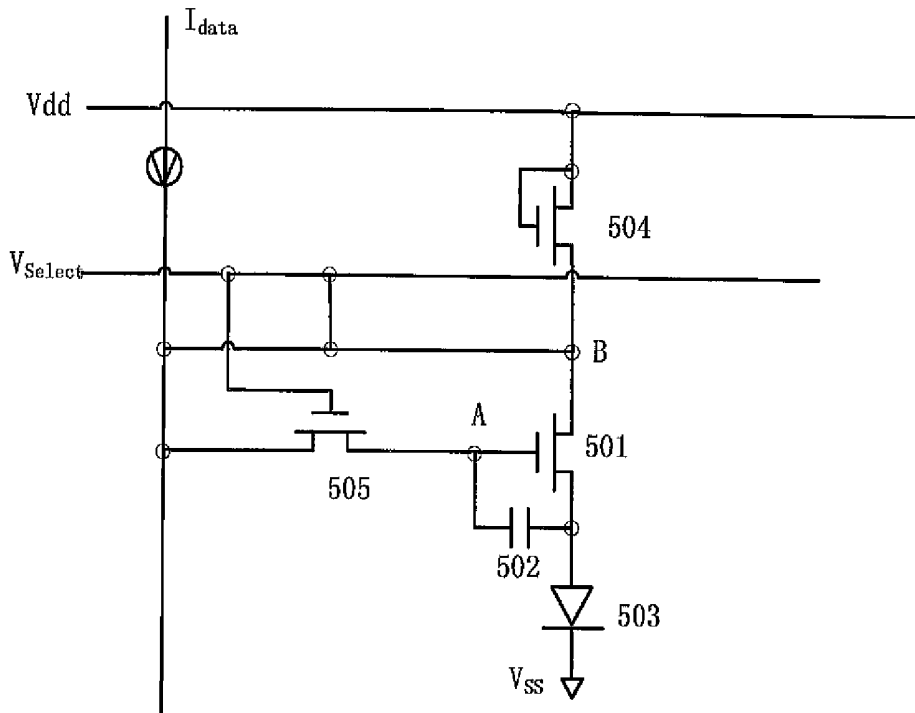

Figure 7

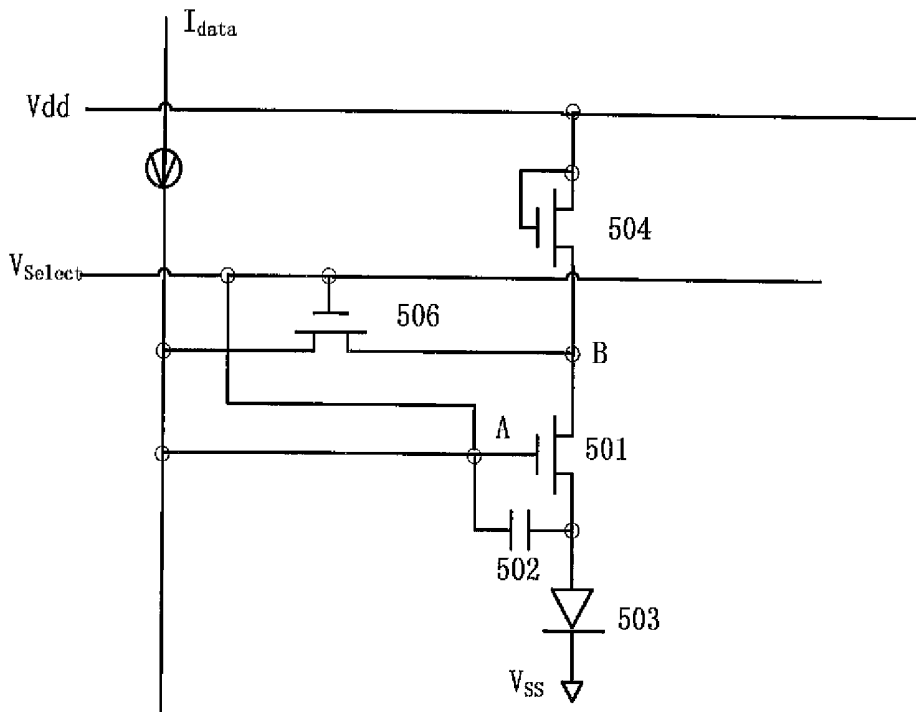

Figure 8

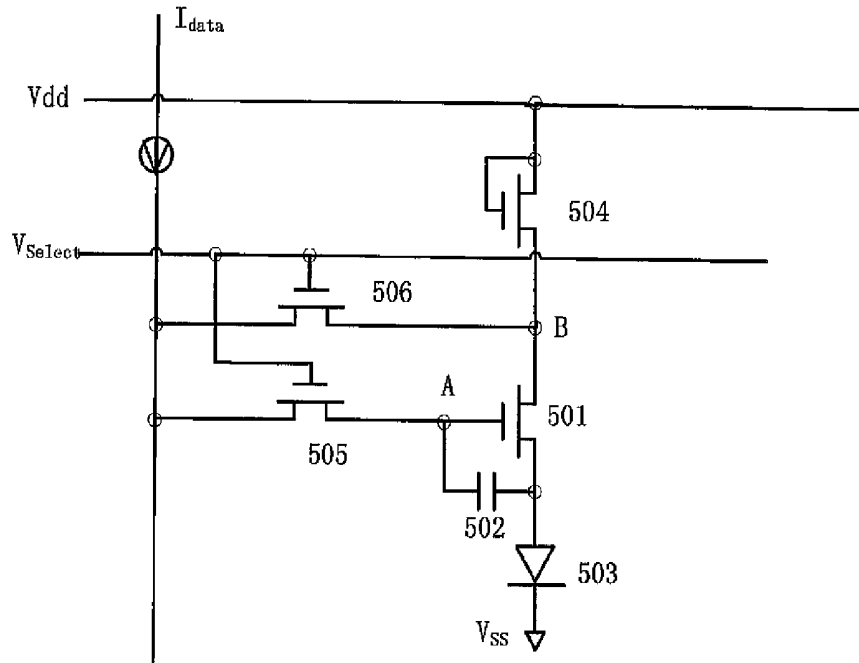

Figure 9

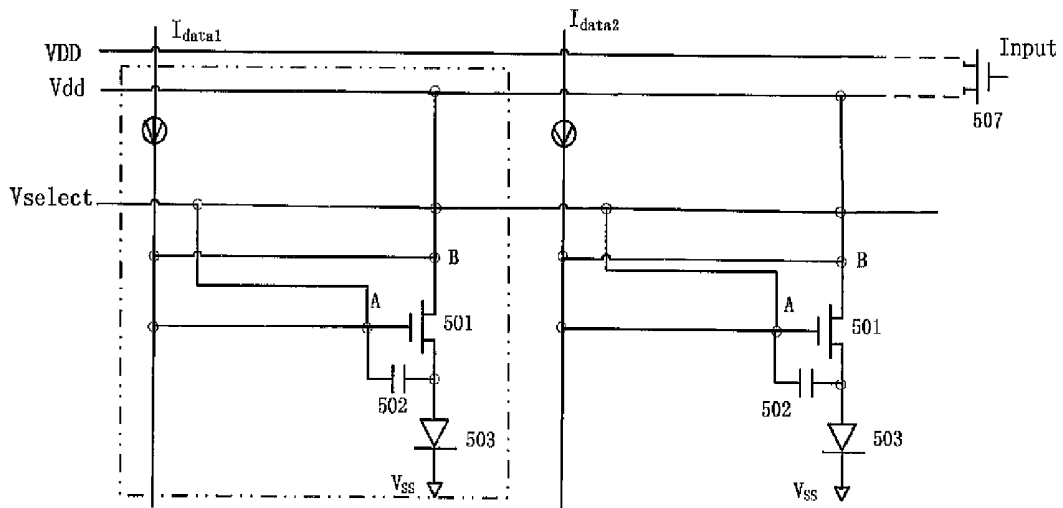

Figure 10

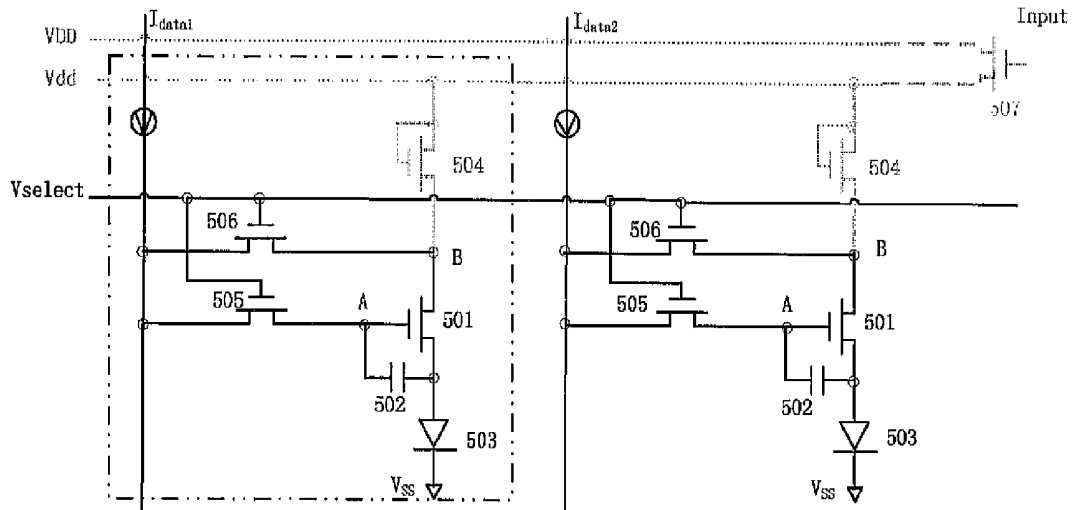

Figure 13

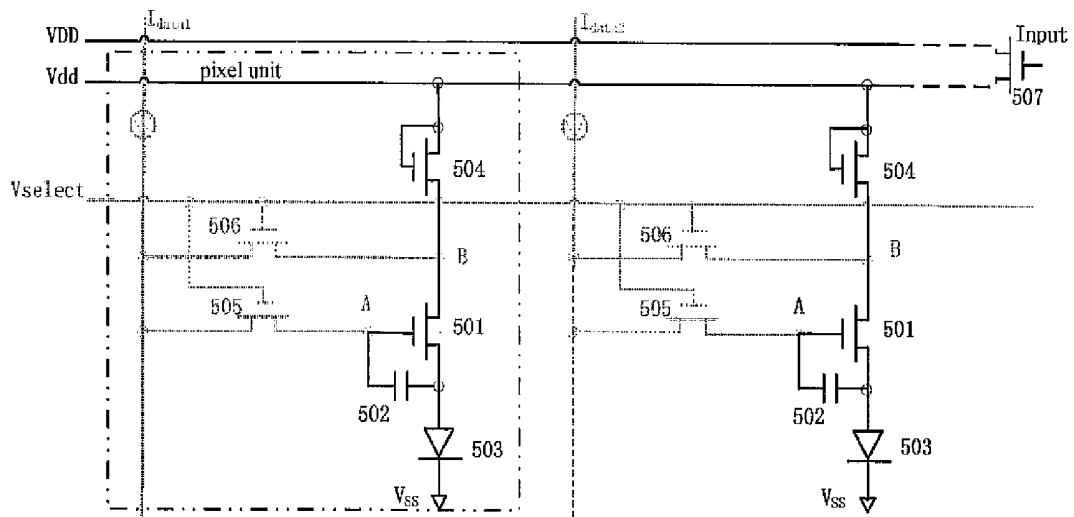

Figure 14

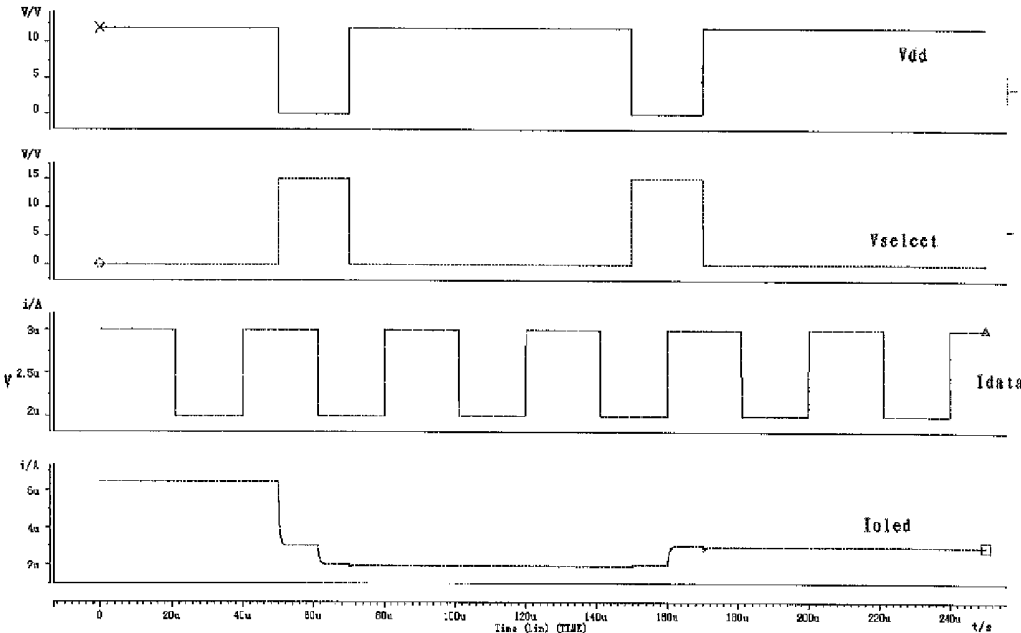

Figure 15

PIXEL CIRCUIT, DRIVING CIRCUIT, ARRAY SUBSTRATE AND DISPLAY DEVICE

TECHNICAL FIELD OF THE DISCLOSURE

[0001] The present disclosure relates to the technical field of organic light emitting display, and particularly to a pixel circuit, a driving circuit, an array substrate and a display device.

BACKGROUND

[0002] The driving methods for an Organic Light Emitting Display (OLED) pixel circuit may be divided into a current-driven method and a voltage-driven method. FIG. 1 shows a voltage-driven pixel circuit, and FIG. 2 shows a current-driven pixel circuit. In the voltage-driven pixel circuit, the formula for the output current I_{OLED} is as follows:

$$I_{OLED} = \frac{1}{2} \mu_n \cdot C_{ox} \cdot \frac{W}{L} \cdot (V_{data} - V_{oled} - V_{th})^2,$$

[0003] where μ_n is a carrier mobility, C_{ox} is a gate oxide capacitance, W/L is a width-to-length ratio of a transistor, V_{data} is a data voltage, V_{oled} is an OLED light emitting operation voltage shared by all pixel units, and V_{th} is a threshold voltage of the transistor. For an enhancement-type Thin Film Transistor (TFT), V_{th} is a positive value. For a depletion-type TFT, V_{th} is a negative value. It can be known that if V_{th} of a pixel varies with time, the output current I_{OLED} of the pixel at different times will be different. The afterimage phenomenon will occur, and a stable display of a Liquid Crystal Display (LCD) temporally cannot be ensured. The advantage of the current-driven method with respect to the voltage-driven method is that the output current I_{OLED} is always equal to the input current I_{data} . In the current-driven pixel circuit, even if the threshold voltage V_{th} of the pixel varies with time, the current-driven pixel circuit can adjust autonomously to ensure that the output current I_{OLED} is always equal to the input current I_{data} , so as to realize a uniform display spatially and a stable display temporally of the LCD. This is because that the operation process of the current-driven pixel circuit may generally be divided into two stages, the first of which is a pre-charging stage, and the second of which is a light emitting stage. At the pre-charging stage, the output current I_{OLED} is equal to the input current I_{data} , at the same time, charge is stored in a capacitor of the current-driven pixel circuit. At the light emitting stage, since the charge has been stored in the capacitor of the current-driven pixel circuit, it can be ensured that the output current I_{OLED} in the current-driven pixel circuit is still equal to the output current I_{OLED} at the pre-charging stage, i.e., still equal to the input current I_{data} at the pre-charging stage. A particular current-driven pixel circuit is as shown in FIG. 3, in the circuit, there is an input terminal of an external control voltage V_{ctrl} for supplying the voltage to the circuit in the light emitting stage, which is connected to a gate of a TFT, and an input terminal of an operation voltage V_{DD} of the circuit is connected to one of a source and a drain of the TFT. A simulated signal waveform chart of the circuit is as shown in FIG. 4. An inverse signal synchronized with the signal input from the input terminal of a pre-charging control voltage V_{select} for supplying the voltage to the circuit in the pre-charging stage is input from the input terminal of the external control voltage V_{ctrl} , to realize a supply of voltage to

the driving circuit by the pre-charging control voltage V_{select} in the pre-charging stage, and a supply of voltage to the circuit by a voltage combined by the external control voltage V_{ctrl} and the operation voltage V_{DD} through a TFT connected thereto, ensuring the output current I_{OLED} of the current-driven pixel circuit existing in the light emitting stage. However, the existence of the external V_{ctrl} input terminal will decrease the aperture ratio of the pixels. With the decrease of the aperture ratio of the pixels, the lifetime of the OLED is decreased.

SUMMARY

[0004] There provide a pixel circuit, a driving circuit, an array substrate and a display device in embodiments of the present disclosure to prolong the lifetime of the OLED employing the current-driven pixel circuit.

[0005] There is provided a pixel circuit comprising: a first thin film transistor whose gate is connected to an input terminal of a pre-charging control voltage and a current input terminal, and drain is connected to the input terminal of the pre-charging control voltage, the current input terminal and an input terminal of a light emitting operation voltage for inputting an inverse signal synchronized with the pre-charging control voltage; a capacitor whose two ends are connected to a source and the gate of the first thin film transistor, respectively; and an organic light emitting diode whose positive pole is connected to the source of the first thin film transistor, and negative pole is connected to an input terminal of a ground voltage.

[0006] Optionally, the drain of the first thin film transistor is connected to the input terminal of the light emitting operation voltage through a diode.

[0007] Optionally, the drain of the first thin film transistor is connected to the input terminal of the light emitting operation voltage through a second thin film transistor; a gate and one of a source and a drain of the second thin film transistor are connected to the input terminal of the light emitting operation voltage, and the other one of the source and the drain is connected to the drain of the first thin film transistor.

[0008] Optionally, the gate and/or the drain of the first thin film transistor is connected to the input terminal of the pre-charging control voltage and the current input terminal through a thin film transistor operating as a switch.

[0009] Optionally, the gate of the first thin film transistor is connected to the input terminal of the pre-charging control voltage and the current input terminal, through a third thin film transistor whose gate is connected to the input terminal of the pre-charging control voltage, one of source and drain is connected to the gate of the first thin film transistor, and the other one of source and drain is connected to the current input terminal; and/or the drain of the first thin film transistor is connected to the input terminal of the pre-charging control voltage and the current input terminal, through a fourth thin film transistor whose gate is connected to the input terminal of the pre-charging control voltage, one of source and drain is connected to the drain of the first thin film transistor, and the other one of source and drain is connected to the current input terminal.

[0010] A driving circuit comprises multiple pixel circuits provided in the embodiments of the present disclosure, the multiple pixel circuits provided in the embodiments of the present disclosure being formed in a matrix; wherein the pixel circuits in the same row of the matrix among the multiple pixel circuits provided in the embodiments of the present

disclosure are connected to the same input terminal of the light emitting operation voltage, and are connected to the same input terminal of the pre-charging control voltage; and the pixel circuits in the same column of the matrix among the multiple pixel circuits provided in the embodiments of the present disclosure are connected to the same current input terminal.

[0011] There is provided an array substrate comprising the driving circuit provided in the embodiments of the present disclosure.

[0012] There is provided a display device comprising the driving circuit provided in the embodiments of the present disclosure.

[0013] There provide in the embodiments of the present disclosure the pixel circuit, the driving circuit, the array substrate and the display device, which are supplied with the voltage by the light emitting operation voltage when the pixel circuit enters the light emitting stage, by inputting an inverse signal synchronized with the pre-charging control voltage at the input terminal of the light emitting operation voltage to ensure a stable output of the current by the circuit in the light emitting stage. Also, it does not require an arrangement of an external voltage input terminal which will decrease the aperture ratio, thereby increasing the aperture ratio of the OLED employing the current-driven pixel circuit while ensuring the stable output of the current by the current-driven circuit, and thus increasing the lifetime of the OLED employing the current-driven pixel circuit.

BRIEF DESCRIPTION OF THE DRAWINGS

[0014] FIG. 1 is a diagram of a voltage-driven pixel circuit as known in the art;

[0015] FIG. 2 is a diagram of a current-driven pixel circuit as known in the art;

[0016] FIG. 3 is a diagram of a particular current-driven pixel circuit as known in the art;

[0017] FIG. 4 is a simulated signal waveform chart of the current-driven pixel circuit in the prior art;

[0018] FIG. 5 is a schematic diagram of a pixel circuit in a first embodiment of the present disclosure;

[0019] FIG. 6 is a schematic diagram of a pixel circuit in a second embodiment of the present disclosure;

[0020] FIG. 7 is a schematic diagram of a pixel circuit in a third embodiment of the present disclosure;

[0021] FIG. 8 is a schematic diagram of a pixel circuit in a fourth embodiment of the present disclosure;

[0022] FIG. 9 is a schematic diagram of a pixel circuit in a fifth embodiment of the present disclosure;

[0023] FIG. 10 is a schematic diagram of a driving circuit in an embodiment of the present disclosure;

[0024] FIG. 11 is a schematic diagram of an alternative driving circuit in the embodiment of the present disclosure;

[0025] FIG. 12 is a simulated waveform chart of an input voltage in the embodiment of the present disclosure;

[0026] FIG. 13 is a schematic circuit diagram of the driving circuit in a pre-charging stage in the embodiment of the present disclosure;

[0027] FIG. 14 is a schematic circuit diagram of the driving circuit in a light emitting stage in the embodiment of the present disclosure; and

[0028] FIG. 15 is a simulated signal waveform chart of an operation process of the driving circuit in the embodiment of the present disclosure.

DETAILED DESCRIPTION

[0029] There provide in the embodiments of the present disclosure a pixel circuit, a driving circuit, an array substrate and a display device, which are supplied with the voltage by the light emitting operation voltage when the pixel circuit enters the light emitting stage, by inputting an inverse signal synchronized with the pre-charging control voltage V_{select} at the input terminal of the light emitting operation voltage. It ensures a stable output of the current by the circuit in the light emitting stage. Also, it does not require an arrangement of an external voltage input terminal which will decrease the aperture ratio, thereby increasing the aperture ratio of the OLED employing the current-driven pixel circuit while ensuring the stable output of the current by the current-driven circuit, and thus increasing the lifetime of the OLED employing the current-driven pixel circuit.

[0030] As shown in FIG. 5, a pixel circuit according to a first embodiment of the present disclosure comprises:

[0031] a first thin film transistor (TFT) **501**, whose gate is connected to an input terminal of a pre-charging control voltage V_{select} and a current input terminal, and drain is connected to the input terminal of the pre-charging control voltage V_{select} , the current input terminal and an input terminal of a light emitting operation voltage V_{dd} for inputting an inverse signal synchronized with the pre-charging control voltage V_{select} ;

[0032] a capacitor **502**, having two ends being connected to a source and the gate of the first TFT **501**, respectively; and

[0033] an organic light emitting diode (LED) **503** whose positive pole is connected to the source of the first TFT **501**, and negative pole is connected to an input terminal of a ground voltage V_{ss} .

[0034] An inverse signal synchronized with the pre-charging control voltage V_{select} is input from the input terminal of the light emitting operation voltage V_{dd} . Therefore, the circuit is supplied with the voltage by the signal input from the input terminal of the pre-charging control voltage V_{select} in the pre-charging stage, and is supplied with the voltage by the signal input from the light emitting operation voltage V_{dd} in the light emitting stage thereby, it is ensured that there is current output in the circuit in the light emitting stage, while the capacitor **502** ensures that the current output in the light emitting stage is the same as that in the pre-charging stage. There is no external signal terminal in the circuit which will affect the aperture ratio, thereby increasing the aperture ratio of the OLED employing the current-driven pixel circuit, and thus increasing the lifetime of the OLED employing the current-driven pixel circuit.

[0035] In the practical application, the drain voltages of the first TFTs **501** of the adjacent pixels will be different when the currents input from the current input terminals of the adjacent pixels in the same row are different, which easily results in the direction of the current in the driving circuit for a pixel with a higher drain voltage is opposite to the direction of the current required in a normal operation, thereby affecting a normal display of the OLED. Therefore, in order to prevent the direction of the current in the driving circuits for the respective pixels from being opposite to the direction of the current required in the normal operation, the drain of the first TFT **501** in the pixel circuit can be connected to the input terminal of the light emitting operation voltage V_{dd} through a diode to ensure that the current of the driving circuit in the light emitting stage is flowed to the drain of the first TFT **501** from the input terminal of the driving voltage.

[0036] Alternatively, for convenience of the manufacture of the OLED, the diode connecting the drain of the first TFT 501 and the input terminal of the light emitting operation voltage V_{dd} can be replaced with a TFT.

[0037] FIG. 6 shows a pixel circuit in the second embodiment of the present disclosure schematically. Specifically, as shown in FIG. 6, the drain of the first TFT 501 can be connected to the input terminal of the light emitting operation voltage V_{dd} through a second TFT 504.

[0038] A gate and one of a source and a drain of the second TFT 504 are connected to the input terminal of the light emitting operation voltage V_{dd}, and the other one of the source and the drain is connected to the drain of the first TFT 501.

[0039] The second TFT 504 in FIG. 6 may be viewed as a diode with a positive pole connected to the input terminal of the light emitting operation voltage V_{dd} and a negative pole connected to the drain of the first TFT 501, thereby ensuring that the direction of the current in the driving circuit is from the input terminal of the light emitting operation voltage V_{dd} to the drain of the first TFT 501.

[0040] Of course, those skilled in the art may employ other feasible ways to prevent the currents input from the current input terminals of the adjacent pixels in the same row from being different and thus affecting the normal display of the OLED. The implementation provided herein is only exemplary and the other implementations will not be described in detail one by one.

[0041] Further, if it needs to progressively drive the driving circuit for the respective pixels, that is, a pre-charging to a next row can only be done after the pre-charging to a previous row is completed, the embodiment of the present disclosure can further provide an alternative way to achieve the progressive driving. That is, the gate and/or the drain of the first TFT 501 can be connected to the input terminal of the pre-charging control voltage V_{select} and the current input terminal through a TFT operating as a switch. The TFT operating as the switch is turned on at a high level and is turned off at a low level. Therefore, different signals are input from the input terminal of the pre-charging control voltage V_{select} of the respective rows of the pixel circuits to realize the progressive driving.

[0042] Specifically, the gate of the first TFT 501 can be connected to the input terminal of the pre-charging control voltage V_{select} and the current input terminal through a TFT operating as a switch.

[0043] FIG. 7 shows a pixel circuit of a third embodiment of the present disclosure schematically. As shown in FIG. 7, the gate of the first TFT 501 may be connected to the input terminal of the pre-charging control voltage V_{select} and the current input terminal through a TFT operating as a switch.

[0044] More specifically, the gate of the first TFT 501 is connected to the input terminal of the pre-charging control voltage V_{select} and the current input terminal through a third TFT 505. The gate of the third TFT 505 is connected to the input terminal of the pre-charging control voltage V_{select}, one of a source and a drain thereof is connected to the gate of the first TFT 501, and the other one of the source and the drain is connected to the current input terminal.

[0045] Further, the drain of the first TFT 501 may also be connected to the input terminal of the pre-charging control voltage V_{select} and the current input terminal through a TFT operating as a switch.

[0046] FIG. 8 shows a diagram of a pixel circuit in a fourth embodiment of the present disclosure schematically. As

shown in FIG. 8, the drain of the first TFT 501 is connected to the input terminal of the pre-charging control voltage V_{select} and the current input terminal through a TFT operating as a switch.

[0047] More specifically, the drain of the first TFT is connected to the input terminal of the pre-charging control voltage V_{select} and the current input terminal through a fourth TFT 506. A gate of the fourth TFT 506 is connected to the input terminal of the pre-charging control voltage V_{select}, one of a source and a drain is connected to the drain of the first TFT 501, and the other one of the source and the drain is connected to the current input terminal.

[0048] Of course, those skilled in the art may also employ other feasible ways to achieve the progressive driving for the pixel circuits. The implementation provided here is only exemplary, and the other implementations will not be described in detail one by one.

[0049] FIG. 9 shows a pixel circuit in a fifth embodiment of the present disclosure schematically. As shown in FIG. 9, an alternative pixel circuit in the embodiment of the present disclosure comprises: a first TFT 501, a second TFT 504, a third TFT 505 and a fourth TFT 506, and further comprises a capacitor 502 and a OLED 503.

[0050] Herein two ends of the capacitor 502 are connected to a source and a gate of the first TFT 501, respectively.

[0051] A positive pole of the OLED 503 is connected to the source of the first TFT 501, and the negative pole of the OLED 503 is connected to an input terminal of a ground voltage V_{ss}.

[0052] A gate and one of a source and a drain of the second TFT 504 are connected to an input terminal of a light emitting operation voltage V_{dd}, and the other one of the source and the drain is connected to a drain of the first TFT 501.

[0053] A gate of the third TFT 505 is connected to an input terminal of a pre-charging control voltage V_{select}, one of a source and a drain of the third TFT 505 is connected to the gate of the first TFT 501, and the other one of the source and the drain is connected to the current input terminal.

[0054] A gate of the fourth TFT 506 is connected to the input terminal of the pre-charging control voltage V_{select}, one of a source and a drain of the fourth TFT 506 is connected to the drain of the first TFT 501, and the other one of the source and the drain is connected to the current input terminal.

[0055] Here, an inverse signal synchronized with the pre-charging control voltage V_{select} is input from the input terminal of the light emitting operation voltage V_{dd}. The circuit is supplied with the voltage by the pre-charging control voltage V_{select} when the pixel circuit enters the pre-charging stage, and is supplied with the voltage by the light emitting operation voltage V_{dd} when the pixel circuit enters the light emitting stage to ensure the current output of the circuit at the pre-charging stage and the light emitting stage. Also, there is no external voltage input terminal which will affect the aperture ratio, thereby increasing the aperture ratio of the OLED employing the current-driven pixel circuit, and further increasing the lifetime of the OLED employing the current-driven pixel circuit. The second TFT 504 may be viewed as a diode with a positive pole being connected to the input terminal of the light emitting operation voltage V_{dd} and a negative pole being connected to the drain of the first TFT 501, thereby ensuring that the direction of the current in the driving circuit is from the input terminal of the light emitting operation voltage V_{dd} to the drain of the first TFT 501. The third TFT 505 and the fourth TFT 506 are TFTs operating as

switch, which are turned on at the high level and turned off at the low level, thereby inputting different signals by the input terminal of the pre-charging control voltage V_{select} of the respective rows of the pixel circuits, so as to achieve the progressive driving.

[0056] There further provides in the embodiment of the present disclosure a driving circuit comprising multiple pixel circuits provided in the embodiments of the present disclosure being formed in a matrix.

[0057] The pixel circuits in the same row of the matrix among the multiple pixel circuits provided in the embodiments of the present disclosure are connected to the same input terminal of the light emitting operation voltage, and are connected to the same input terminal of the pre-charging control voltage.

[0058] The pixel circuits in the same column of the matrix among the multiple pixel circuits provided in the embodiments of the present disclosure are connected to the same current input terminal.

[0059] FIG. 10 shows a driving circuit in an embodiment of the present disclosure schematically. Alternatively, as shown in FIG. 10, the driving circuit provided in the embodiment of the present disclosure comprises multiple pixel circuits forming a matrix. In FIG. 10, the pixel circuits in the first column of the matrix among the multiple pixel circuits provided in the embodiment of the present disclosure comprises a fifth TFT 507.

[0060] A source and a drain of the fifth TFT 507 are connected to the input terminal of the light emitting operation voltage V_{dd} and an input terminal of an operation voltage V_{DD} respectively, a gate of the fifth TFT 507 is connected to a signal input terminal Input for inputting an inverse signal synchronized with the pre-charging control voltage V_{select} , and the fifth TFT 507 is a N-type TFT.

[0061] The fifth TFT 507 is arranged in the pixel circuits in the first column of the matrix among the multiple pixel circuits provided in the embodiment of the present disclosure. By inputting an inverse signal synchronized with the pre-charging control voltage V_{select} at the gate of the fifth TFT 507 and connecting the input terminal of the light emitting operation voltage V_{dd} and the input terminal of the operation voltage V_{DD} at the source and the drain thereof respectively, the signal output from one of the source and the drain of the fifth TFT 507 which is connected to the input terminal of the light emitting operation voltage V_{dd} is the signal input to the pixel circuits from the input terminal of the light emitting operation voltage V_{dd} . After the signal is input from the input terminal of the operation voltage V_{DD} and the input terminal of the pre-charging control voltage V_{select} , signal output from the one of the source and the drain of the fifth TFT 507 which is connected to the input terminal of the light emitting operation voltage V_{dd} is the inverse signal synchronized with the pre-charging control voltage V_{select} , thereby ensuring that the signal input to the pixel circuits from the input terminal of the light emitting operation voltage V_{dd} is the inverse signal synchronized with the pre-charging control voltage V_{select} .

[0062] Of course, those skilled in the art may employ other feasible ways to ensure that the signal input to the pixel circuits from the input terminal of the light emitting operation voltage V_{dd} is the inverse signal synchronized with the pre-charging control voltage V_{select} . The implementation provided here is only exemplary, and the other implementations will not be described in detail one by one.

[0063] FIG. 11 shows an alternative driving circuit in the embodiment of the present disclosure. As shown in FIG. 11, there is provided in the embodiment of the present disclosure an exemplary driving circuit, which comprises multiple pixel circuits forming a matrix.

[0064] The pixel circuit comprises: a first TFT 501, a second TFT 504, a third TFT 505, a fourth TFT 506 and a fifth TFT 507, and further comprises a capacitor 502 and a OLED 503.

[0065] Two ends of the capacitor 502 are connected to a source and a gate of the first TFT 501, respectively.

[0066] A positive pole of the OLED 503 is connected to the source of the first TFT 501, and the negative pole of the OLED 503 is connected to an input terminal of a ground voltage V_{ss} .

[0067] A gate and one of a source and a drain of the second TFT 504 are connected to an input terminal of a light emitting operation voltage V_{dd} , and the other one of the source and the drain is connected to a drain of the first TFT 501.

[0068] A gate of the third TFT 505 is connected to an input terminal of a pre-charging control voltage V_{select} , one of a source and a drain of the third TFT 505 is connected to the gate of the first TFT 501, and the other one of the source and the drain is connected to the current input terminal.

[0069] A gate of the fourth TFT 506 is connected to the input terminal of the pre-charging control voltage V_{select} , one of a source and a drain of the fourth TFT 506 is connected to the drain of the first TFT 501, and the other one of the source and the drain is connected to the current input terminal.

[0070] A source and a drain of the fifth TFT 507 in the pixel circuits of the first column of the matrix among the multiple pixel circuits are connected respectively to the input terminal of the light emitting operation voltage V_{dd} and an input terminal of an operation voltage V_{DD} . A gate of the fifth TFT 507 is connected to a signal input terminal Input for inputting an inverse signal synchronized with the pre-charging control voltage V_{select} , and the fifth TFT 507 is a N-type TFT. Exemplarily, as shown in FIG. 12, the signal input from the input terminal of the operation voltage V_{DD} may also be opposite to the signal input from the input terminal of the pre-charging control voltage V_{select} .

[0071] The pixel circuits in the same row of the matrix among the multiple pixel circuits are connected to the same input terminal of the light emitting operation voltage, and are connected to the same input terminal of the pre-charging control voltage.

[0072] The pixel circuits in the same column of the matrix among the multiple pixel circuits are connected to the same current input terminal.

[0073] In the following, the operation principle of the driving circuit shown in FIG. 11 will be described by way of example in detail.

[0074] FIG. 13 shows schematically a circuit in the pre-charging stage of the driving circuit according to the embodiment of the present disclosure. As shown in FIG. 13, in the pre-charging stage, the pre-charging control voltage V_{select} is the high level, and the light emitting operation voltage V_{dd} is the low level. At this time, the fifth TFT 507 and the second TFT 504 are turned off, and the third TFT 505 and the fourth TFT 506 are turned on. The voltages at the gate (point A) and the drain (point B) of the first TFT 501 are equal, $V_{ds} > V_{gs} - V_{th}$, where V_{ds} is the source-drain voltage and V_{gs} is the source-gate voltage. At this time, the first TFT 501 is in the saturated region, the current I_{data} is flowed into the first TFT

501 through the fourth TFT **506**, the capacitor **502** stores charges to maintain the source-gate voltage V_{gs} of the first TFT **501**, and the output current I_{OLED} is equal to I_{data} at this time.

[0075] FIG. 14 shows schematically a circuit in the light emitting stage of the driving circuit according to the embodiment of the present disclosure. As shown in FIG. 14, in the light emitting stage, the pre-charging control voltage V_{select} is the low level, and the light emitting operation voltage V_{dd} is the high level. At this time, the third TFT **505** and the fourth TFT **506** are turned off, and the second TFT **504** and the fifth TFT **507** are turned on. The voltage at the drain (point B) of the first TFT **501** is the high level. The first TFT **501** is still in the saturated region, the output current of the transistor at this time will maintain the value when the transistor enters the saturated region. Therefore, the output current I_{OLED} in the light emitting stage is still I_{data} in the pre-charging stage, and the output current remains unchanged.

[0076] It can be known that the output current of the driving circuit shown in FIG. 11 is only related to the input current, and is unrelated with the threshold voltage V_{th} . Therefore, the effect of the non-uniformity of the threshold voltage on the display is basically eliminated, the output current is stable, and it is easy to realize a high brightness and a high resolution of the display.

[0077] FIG. 15 shows a simulated signal waveform chart of the operation process of the driving circuit in the embodiment of the present disclosure. FIG. 15 is a simulation result of the driving circuit shown in FIG. 11. The simulation shows two operation cycles of a single sub pixel. In the first cycle, the pixel is written with the current of 2 μA . In the second cycle, the pixel is written with the current of 3 μA . It can be seen obviously from the waveform chart that the output current I_{OLED} of the pixel follows the change of the input current I_{data} very well, after the circuit is pre-charged.

[0078] There is further provided in the embodiment of the present disclosure an array substrate comprising the driving circuit provided in the embodiments of the present disclosure.

[0079] There is provided in the embodiment of the present disclosure a display device comprising the driving circuit provided in the embodiments of the present disclosure.

[0080] The embodiments of the present disclosure provide a pixel circuit, a driving circuit, an array substrate and a display device, which are supplied with the voltage by the light emitting operation voltage V_{dd} when the pixel circuit enters the light emitting stage, by inputting an inverse signal synchronized with the pre-charging control voltage V_{select} at the input terminal of the light emitting operation voltage V_{dd} to ensure a stable output of the current by the circuit at the light emitting stage. Also, there is no external voltage input terminal which will affect the aperture ratio, thereby increasing the aperture ratio of the OLED employing the current-driven pixel circuit while ensuring the stable output of the current by the current-driven circuit, and thus increasing the lifetime of the OLED employing the current-driven pixel circuit.

[0081] Obviously, those skilled in the art can make modifications and variations to the embodiments of the present disclosure without departing from the spirit and the scope of the present disclosure. Hence, it is intended to include these modifications and variations in the present disclosure as long as these modifications and variations belong to the scope of the claims of the present disclosure and the equivalents thereto.

1. A pixel circuit, comprising:

a first thin film transistor whose gate is connected to an input terminal of a pre-charging control voltage and a current input terminal, and drain is connected to the input terminal of the pre-charging control voltage, the current input terminal and an input terminal of a light emitting operation voltage for inputting an inverse signal synchronized with the pre-charging control voltage; a capacitor whose two ends are connected to a source and the gate of the first thin film transistor, respectively; and an organic light emitting diode whose positive pole is connected to the source of the first thin film transistor, and negative pole is connected to an input terminal of a ground voltage.

2. The circuit of claim 1, wherein the drain of the first thin film transistor is connected to the input terminal of the light emitting operation voltage through a diode.

3. The circuit of claim 1, wherein the drain of the first thin film transistor is connected to the input terminal of the light emitting operation voltage through a second thin film transistor;

a gate and one of a source and a drain of the second thin film transistor are connected to the input terminal of the light emitting operation voltage, and the other one of the source and the drain is connected to the drain of the first thin film transistor.

4. The circuit of claim 1, wherein the gate of the first thin film transistor is connected to the input terminal of the pre-charging control voltage and the current input terminal through a thin film transistor operating as a switch.

5. The circuit of claim 1, wherein the drain of the first thin film transistor is connected to the input terminal of the pre-charging control voltage and the current input terminal through a thin film transistor operating as a switch.

6. The circuit of claim 4, wherein

the gate of the first thin film transistor is connected to the input terminal of the pre-charging control voltage and the current input terminal, through a third thin film transistor whose gate is connected to the input terminal of the pre-charging control voltage, one of source and drain is connected to the gate of the first thin film transistor, and the other one of source and drain is connected to the current input terminal.

7. The circuit of claim 5, wherein

the drain of the first thin film transistor is connected to the input terminal of the pre-charging control voltage and the current input terminal, through a fourth thin film transistor whose gate is connected to the input terminal of the pre-charging control voltage, one of source and drain is connected to the drain of the first thin film transistor, and the other one of source and drain is connected to the current input terminal.

8. The circuit of claim 4, wherein

the gate of the first thin film transistor is connected to the input terminal of the pre-charging control voltage and the current input terminal, through a third thin film transistor whose gate is connected to the input terminal of the pre-charging control voltage, one of source and drain is connected to the gate of the first thin film transistor, and the other one of source and drain is connected to the current input terminal; and

the drain of the first thin film transistor is connected to the input terminal of the pre-charging control voltage and the current input terminal, through a fourth thin film

transistor whose gate is connected to the input terminal of the pre-charging control voltage, one of source and drain is connected to the drain of the first thin film transistor, and the other one of source and drain is connected to the current input terminal.

9. A driving circuit comprising multiple pixel circuits of claim 1 formed in a matrix;

wherein the pixel circuits in the same row of the matrix among the multiple pixel circuits are connected to the same input terminal of the light emitting operation voltage, and are connected to the same input terminal of the pre-charging control voltage; and

the pixel circuits in the same column of the matrix among the multiple pixel circuits are connected to the same current input terminal.

10. The driving circuit of claim 9, wherein the pixel circuits in a first column of the matrix among the multiple pixel circuits of claim 1 comprise a fifth thin film transistor;

a source and a drain of the fifth thin film transistor are connected to the input terminal of the light emitting operation voltage and an input terminal of an operation voltage respectively, and a gate thereof is connected to a signal input terminal for inputting an inverse signal synchronized with the pre-charging control voltage, and the fifth thin film transistor is a N-type thin film transistor.

11. An array substrate comprising the driving circuit of claim 9.

12. (canceled)

13. The array substrate of claim 11, wherein the pixel circuits in a first column of the matrix among the multiple pixel circuits comprise a fifth thin film transistor;

a source and a drain of the fifth thin film transistor are connected to the input terminal of the light emitting operation voltage and an input terminal of an operation voltage respectively, and a gate thereof is connected to a signal input terminal for inputting an inverse signal synchronized with the pre-charging control voltage, and the fifth thin film transistor is a N-type thin film transistor.

14. The driving circuit of claim 9, wherein the drain of the first thin film transistor is connected to the input terminal of the light emitting operation voltage through a diode.

15. The driving circuit of claim 9, wherein the drain of the first thin film transistor is connected to the input terminal of the light emitting operation voltage through a second thin film transistor;

a gate and one of a source and a drain of the second thin film transistor are connected to the input terminal of the light

emitting operation voltage, and the other one of the source and the drain is connected to the drain of the first thin film transistor.

16. The driving circuit of claim 9, wherein the gate of the first thin film transistor is connected to the input terminal of the pre-charging control voltage and the current input terminal through a thin film transistor operating as a switch.

17. The driving circuit of claim 9, wherein the drain of the first thin film transistor is connected to the input terminal of the pre-charging control voltage and the current input terminal through a thin film transistor operating as a switch.

18. The driving circuit of claim 16, wherein

the gate of the first thin film transistor is connected to the input terminal of the pre-charging control voltage and the current input terminal, through a third thin film transistor whose gate is connected to the input terminal of the pre-charging control voltage, one of source and drain is connected to the gate of the first thin film transistor, and the other one of source and drain is connected to the current input terminal.

19. The driving circuit of claim 17, wherein

the drain of the first thin film transistor is connected to the input terminal of the pre-charging control voltage and the current input terminal, through a fourth thin film transistor whose gate is connected to the input terminal of the pre-charging control voltage, one of source and drain is connected to the drain of the first thin film transistor, and the other one of source and drain is connected to the current input terminal.

20. The driving circuit of claim 16, wherein

the gate of the first thin film transistor is connected to the input terminal of the pre-charging control voltage and the current input terminal, through a third thin film transistor whose gate is connected to the input terminal of the pre-charging control voltage, one of source and drain is connected to the gate of the first thin film transistor, and the other one of source and drain is connected to the current input terminal; and

the drain of the first thin film transistor is connected to the input terminal of the pre-charging control voltage and the current input terminal, through a fourth thin film transistor whose gate is connected to the input terminal of the pre-charging control voltage, one of source and drain is connected to the drain of the first thin film transistor, and the other one of source and drain is connected to the current input terminal.

* * * * *

专利名称(译)	像素电路，驱动电路，阵列基板和显示装置		
公开(公告)号	US20160163263A1	公开(公告)日	2016-06-09
申请号	US14/366865	申请日	2013-12-12
[标]申请(专利权)人(译)	京东方科技集团股份有限公司		
申请(专利权)人(译)	京东方科技集团股份有限公司.		
当前申请(专利权)人(译)	京东方科技集团股份有限公司.		
[标]发明人	DUAN LIYE WANG LIRONG WU ZHONGYUAN		
发明人	DUAN, LIYE WANG, LIRONG WU, ZHONGYUAN		
IPC分类号	G09G3/32		
CPC分类号	G09G3/3258 G09G3/3283 G09G2300/0809 G09G2320/043 G09G2310/0264 G09G3/325 G09G2300/0465 G09G2300/0819 G09G2300/0842 G09G2300/0861 G09G2300/0866 G09G2300/089 G09G2310/0251		
优先权	201310407319.1 2013-09-09 CN		
其他公开文献	US10276097		
外部链接	Espacenet USPTO		

摘要(译)

本公开涉及OLED显示技术。提供了一种像素电路，驱动电路，阵列基板和显示装置，当像素电路进入发光级时，通过输入与前置同步的反向信号，通过发光操作电压提供电压。- 在发光操作电压的输入端子处对控制电压进行充电，以确保在发光阶段电路的电流稳定输出。而且，不需要布置外部电压输入端子，这会影响到开口率，从而增加采用电流驱动像素电路的OLED的开口率，同时确保电流驱动电路稳定输出电流因此，增加了采用电流驱动像素电路的OLED的寿命。

